

END OF LIFE DOCUMENT

UV-L 110

ITEM	NAME	MATERIAL	QTY	PART NUMBER
1	BOTTOM COVER	METAL SHEET	1	F110_BOTTOM COVER
2	COVER	METAL SHEET	1	F110_COVER
3	BASE	METAL SHEET	1	F110_BASE
4	GRILLE BRACKET	METAL SHEET	3	F110_GRILLE BRACKET
5	BALLAST	ELECTRONIC MATERIAL	1	F110 BALLAST
6	WALL BRACKET	METAL SHEET	1	F110_WALL BRACKET
7	BODY BRACKET	METAL SHEET	1	F110_BODY BRACKET
8	POWER PCB	ELECTRONIC MATERIAL	1	F110_POWER PCB
9	LAMP BRACKET	METAL SHEET	4	F110_LAMP BRACKET
10	SOCKET	METAL SHEET, PLASTIC	4	F110_L_SOCKET
11	VENTILATOR ASSEMBLY		1	SEE SEPARATE SHEET
12	GRILLE	ABS PLASTIC	1	F110_GRILLE

UVC VENTILATOR 110 W/1

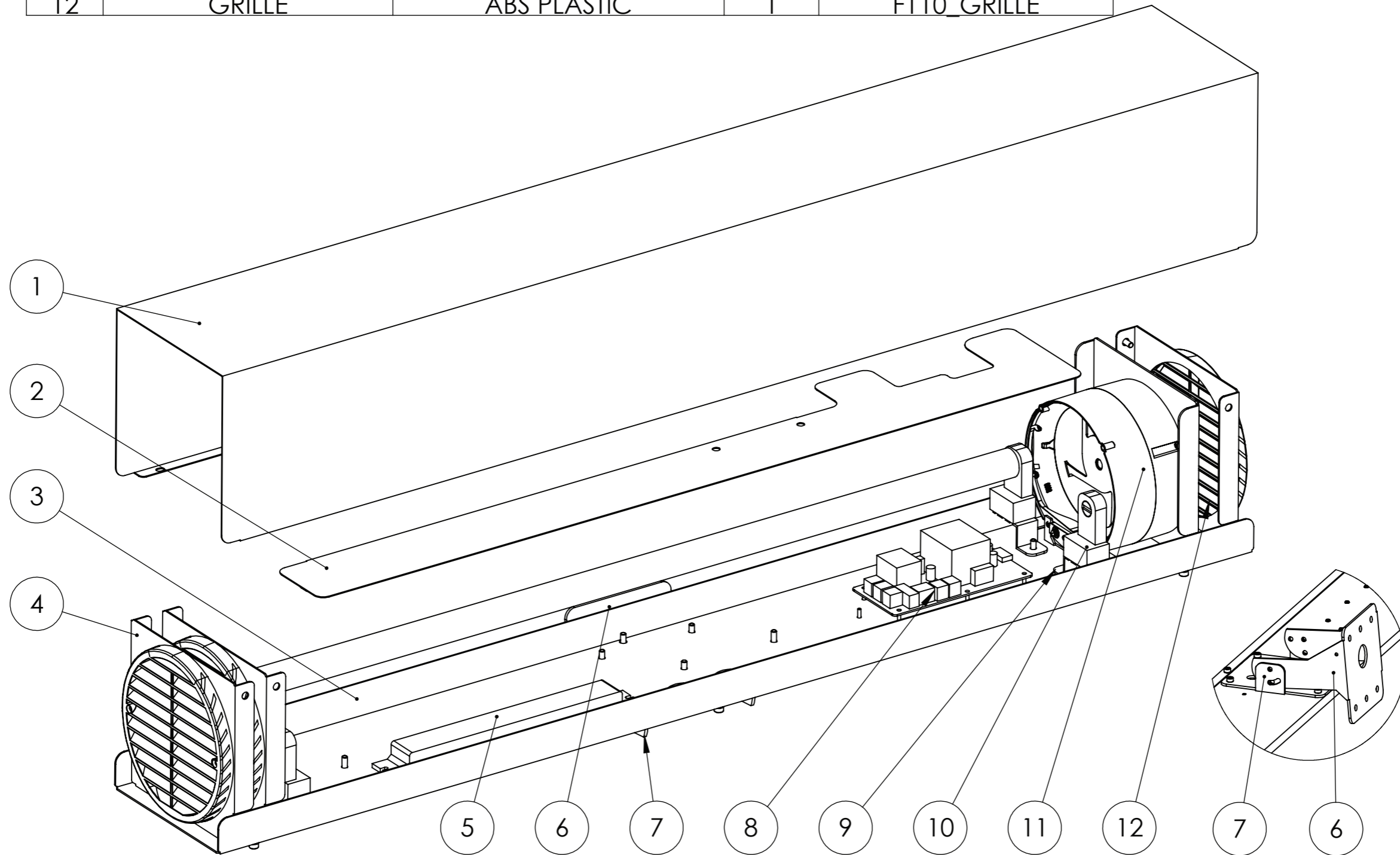

UVC VENTILATOR 110 W/2
 UVC VENTILATOR 55 W/2

ITEM	NAME	MATERIAL	QTY	PART NUMBER
1	FAN BRACKET_1	METAL SHEET	1	F110_FAN_BRACKET_1
2	VENTILATOR HOUSING_1	ABS	1	F110_VENTILATOR HOUSING_1
3	VENTILATOR HOUSING_2	ABS	1	F110_VENTILATOR HOUSING_2
4	VENTILATOR	ELECTRONIC MATERIAL	1	F110_VENTILATOR
5	VENTILATOR_PCB	ELECTRONIC MATERIAL	1	F110_PCB_SIMPLE
		ELECTRONIC MATERIAL		F110_PCB_WIRELESS*
6	FAN BRACKET_2	METAL SHEET	1	F110_WALL_BRACKET
7	M3X10_SCREW_HEX	METAL SHEET	6	F110_BODY_BRACKET

* TYPE OF PCB DEPEND ON MODEL

